

DUAL-FLEX MARINE & INDUSTRIAL ENGINE VIBRATION ISOLATORS DF-242- SERIES

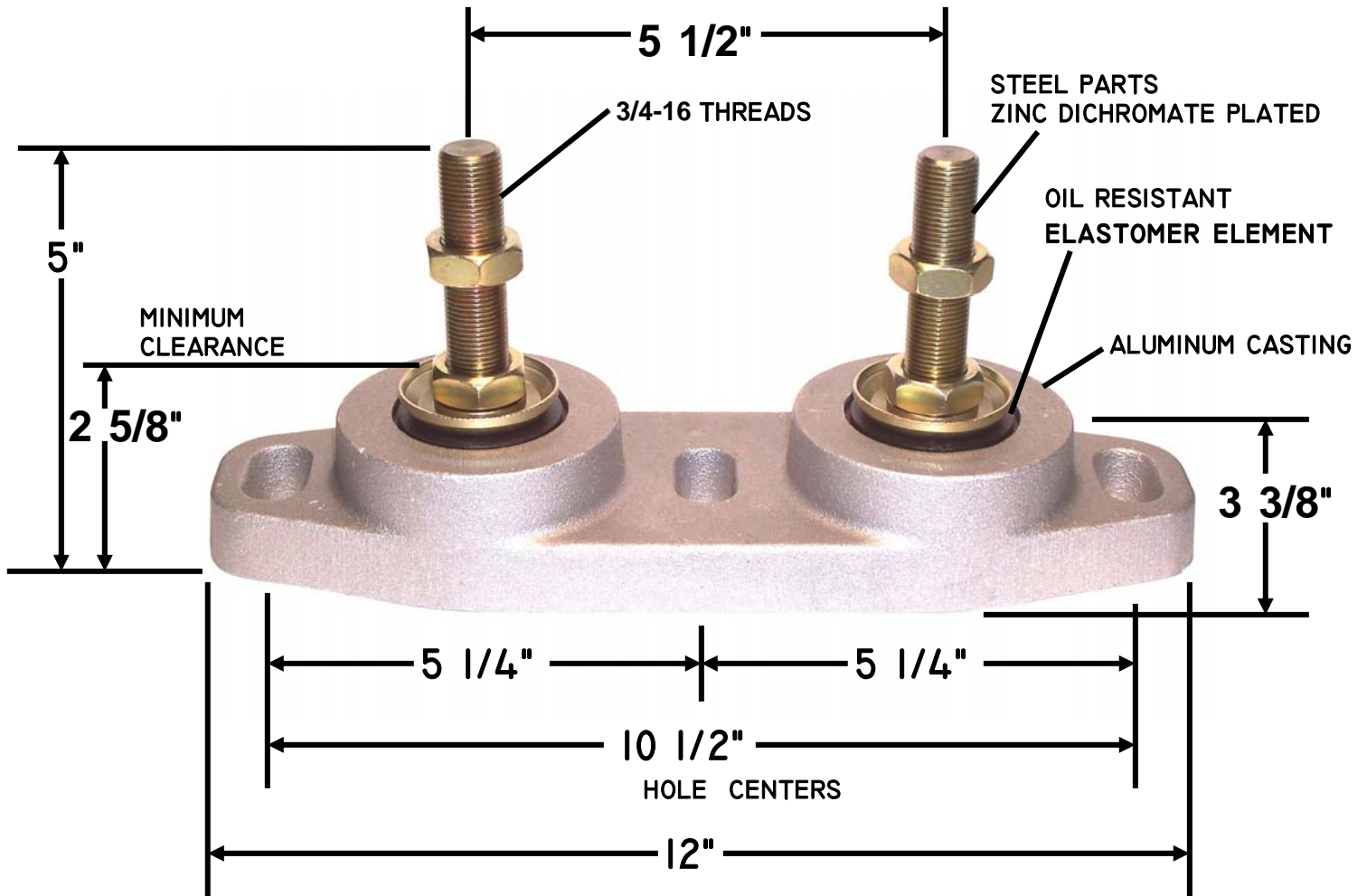

Manufactured in U.S.A.

DF-242 SERIES

The ("Dual Flex") DF-242 Series of heavy duty mountings is a twin stud double mount designed principally for diesel engines from 2,200 up to 3,500 lbs. in weight. Base casting features heavy duty aluminum alloy construction, with lip incorporated in the top of the casting to resist the upward pull of the engine. Durable oil and fuel resistant elastomer element. Low profile mount - requires only 2 5/8" minimum clearance from casting base to top of leveling nut. Fail safe design - bottom pad prevents excessive impact. Easy installation with 3/4"

threaded studs for vertical height and slotted casting for horizontal adjustment. Mounts come complete - furnished with leveling, and locking nuts. Aluminum base cast with three 5/8" slotted mounting holes on 10 1/2" centers. All steel parts are zinc dichromate plated for corrosion resistance. Available in four size ratings (shown below) dependant on engine/powertrain package weight.

SUGGESTED MOUNTINGS	
ENGINE WEIGHTS	4 POINT MOUNTINGS
2,200 to 2,600 lbs.	DF-242
2,600 to 2,900 lbs.	DF-243
2,900 to 3,200 lbs.	DF-244
3,200 to 3,500 lbs.	DF-245

The Bushings, Inc. "Dual Flex" Marine Engine Mount design provides outstanding vibration isolation control across the three (longitudinal, lateral, and vertical) fields of vibratory motion. Construction of the mount gives a soft cushioning effect under normal loads, as mount loads increase across the operating range, shear resistance grows quickly providing smooth operation with a small amount of deflection.



BUSHINGS, INC.

**1967 Rochester Industrial Drive
Rochester Hills, Michigan 48309-3340
Phone:(248)650-0603 Fax:(248)650-0606
www.bushingsinc.com**

