

# DUAL-FLEX MARINE & INDUSTRIAL ENGINE VIBRATION ISOLATORS DF-3300 SERIES

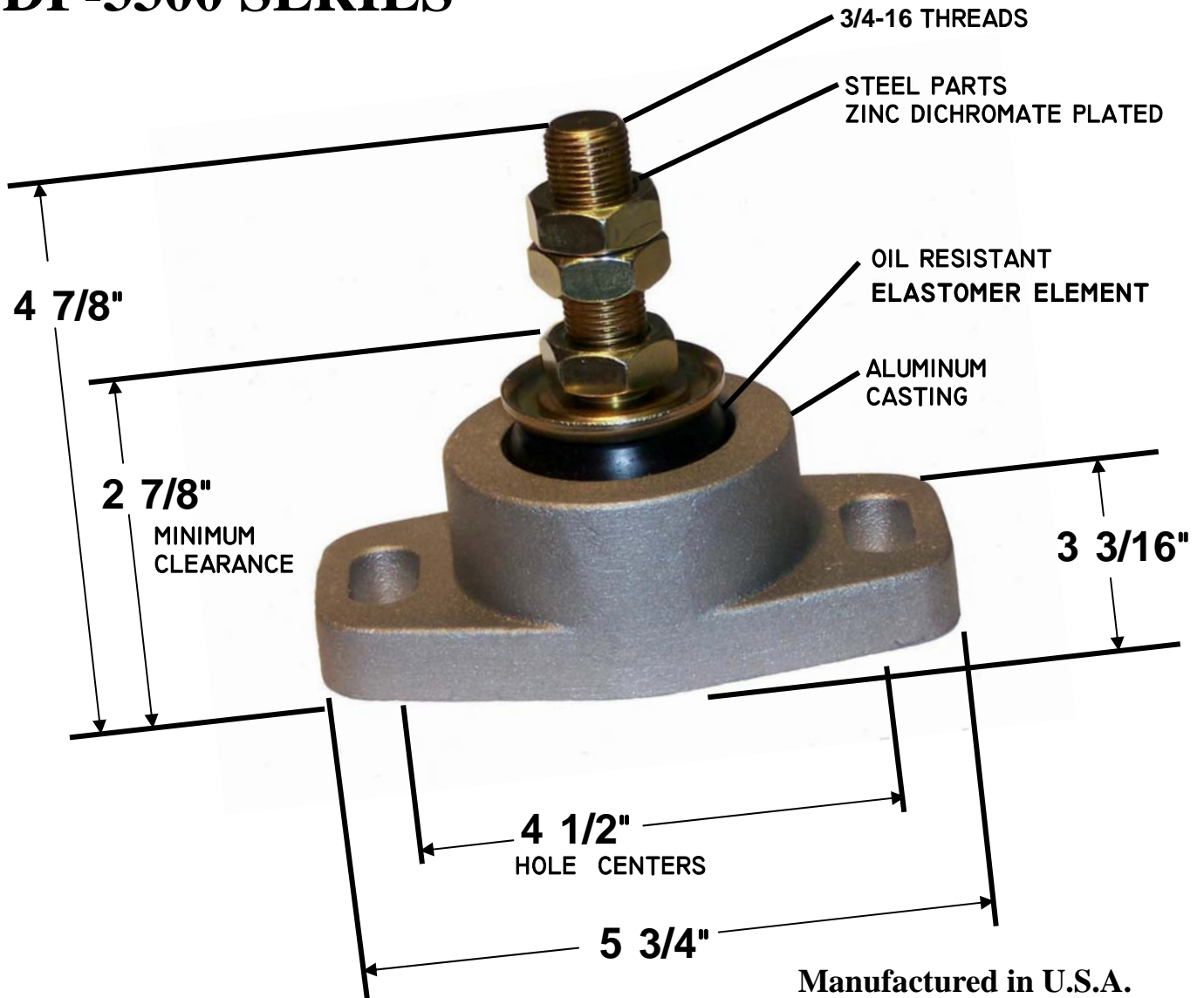

## DF-3300 SERIES

The ("Dual Flex") DF-3300 Series features heavy duty aluminum alloy construction with lip incorporated in the top of the casting to resist the upward pull of the engine. Durable oil and fuel resistant elastomer element raised above top of the casting to accommodate engine mounting angles. Low profile mount-requires only 2 7/8" minimum clearance from casting base to top of leveling nut. Fail safe design - bottom pad prevents excessive impact. Easy installation with threaded

stud for vertical height and slotted casting for horizontal adjustment. Stud furnished with three nuts. Leveling, locking and secondary lock. Aluminum base cast with 1/2" slotted holes for 1/2" bolts or lag screws. All steel parts are zinc dichromate plated for corrosion resistance. Available with 3/4" stud in three size ratings dependant on engine/powertrain package weight.

<b>SUGGESTED MOUNTINGS</b>	
<b>ENGINE WEIGHTS</b>	<b>4 POINT MOUNTINGS</b>
750 to 1,000 lbs.	DF-3304-3
1,000 to 1,400 lbs.	DF-3306-3
1,400 to 1,600 lbs.	DF-3307-3

The Bushings, Inc. "Dual Flex" Marine Engine Mount design provides outstanding vibration isolation control across the three (longitudinal, lateral, and vertical) fields of vibratory motion. Construction of the mount gives a soft cushioning effect under normal loads, as mount loads increase across the operating range, shear resistance grows quickly providing smooth operation with a small amount of deflection.



## **BUSHINGS, INC.**

1967 Rochester Industrial Drive  
Rochester Hills, Michigan 48309-3340  
Phone:(248)650-0603 Fax:(248)650-0606  
[www.bushingsinc.com](http://www.bushingsinc.com)

